

IPTC 11542

## Mobile Robots for Offshore Inspection and Manipulation

Birgit Graf, Kai Pfeiffer, and Harald Staab, Fraunhofer IPA, www.offshore-robotics.com

Copyright 2007, International Petroleum Technology Conference

This paper was prepared for presentation at the International Petroleum Technology Conference held in Dubai, U.A.E., 4-6 December 2007.

This paper was selected for presentation by an IPTC Programme Committee following review of information contained in an abstract submitted by the author(s). Contents of the paper, as presented, have not been reviewed by the International Petroleum Technology Conference and are subject to correction by the author(s). The material, as presented, does not necessarily reflect any position of the International Petroleum Technology Conference, its officers, or members. Papers presented at IPTC are subject to publication review by Sponsor Society Committees of IPTC. Electronic reproduction, distribution, or storage of any part of this paper for commercial purposes without the written consent of the International Petroleum Technology Conference is prohibited. Permission to reproduce in print is restricted to an abstract of not more than 300 words; illustrations may not be copied. The abstract must contain conspicuous acknowledgment of where and by whom the paper was presented. Write Librarian, IPTC, P.O. Box 833836, Richardson, TX 75083-3836, U.S.A., fax 01-972-952-9435.

### Abstract

This paper analyzes the potential to apply mobile service robots in offshore oil and gas producing environments. The required hardware and software components and abilities of such a mobile offshore inspection and manipulation robot are presented in this paper.

Possible applications of mobile service robots in an offshore environment range from simple visual inspection tasks to physical intervention with the process equipment, e.g. for sample taking, valve turning, cleaning up minor obstructions, and operating control panels.

The first prototype of a mobile offshore inspection robot is equipped with a robotic arm which carries a camera for visual inspection as well as various application sensors such as a microphone, gas and fire sensors. It is able of both, remote and autonomous inspection of industrial process equipment. In automatic mode the robot autonomously executes pre-programmed inspection tasks. The results of all inspection tasks are saved to a database and can be reviewed by the responsible operator in the central control room at any time.

The evaluation of the first autonomous mobile robot that has ever been operated in offshore environments has proven the applicability of mobile robotics to offshore environments. Different types of inspection tasks (visual and acoustic inspection, gas measuring) have been programmed to and executed by the robot successfully without ever jeopardizing the safety of the platform or the platform personnel.

The application of mobile robotics in offshore environments can reduce the level of manual human intervention required to operate a production facility thereby increasing the efficiency of the workforce, improving safety and working conditions, and improving the production economics. The successful evaluation of the first realization of a mobile inspection and manipulation robot has thus levelled the ground for future mobile robot installations in offshore environments.

### Introduction

Commercial mobile robots are already applied successfully in different operation areas such as underwater inspection, cleaning, defence, rescue, and security. According to the "World Robotics Study" conducted yearly by the International Federation of Robotics (IFR), a significant increase in advanced field and mobile service robot installations is predicted for the next years (Fig. 1).

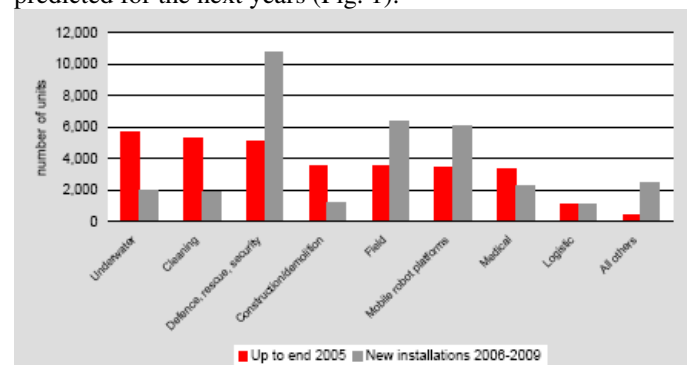

Fig. 1: Current and projected installations of service robots for professional use [1].

In the oil and gas industry, a small number of robotic devices is used in exploration and production, for example for pipe and underwater inspection and repair [2]. These devices, however, are purely remote controlled vehicles and thus require the constant control by a user during operation.

The operation of semi-autonomous or fully autonomous mobile robots on an offshore oil and gas platform can reduce the level of manual human intervention required to operate the production facility, thereby increasing the efficiency of the workforce and improving safety, working conditions, and production economics. Even though the idea of applying mobile robots for assistive tasks in offshore environments and process plants is not new [3,4], no implementations of mobile robots in real offshore environments could be observed so far.

### Offshore Application of Mobile Robots

Offshore platform operators spend a large amount of time with walking, transporting things, and doing regular inspection and maintenance tasks. A mobile robot for offshore inspection and manipulation can be applied to automate such frequent but simple tasks, specifically

- regular supervision and maintenance tasks as well as occasional tasks evolving from operation requirements,
- activities with or without mechanical contact to the environment.

To execute the given tasks, the robot may operate autonomously or may be tele-operated by a remote user.

Remote operation of the robot includes short distance wireless connections, for example from the central control room to another location on the same platform as well as long distance connections, for example from an onshore control station or a neighbouring offshore platform.

An interesting application for tele-operated mobile robots may be the regular maintenance of unmanned platforms. Occasional operations in tele-operated mode cover the handling of valves and levers, for example to change the pressure or the flow rate and to operate electrical control panels, for example to start or stop the operation of specific devices.

On both, manned or unmanned platforms, the robot could be applied to check on detected gas leakages or fires as well as it could carry out first intervention activities such as fire fighting and closing valves. Applying a robot in such critical situations could minimize human exposure to a hazard and thus improve the overall safety of the platform personnel.

A large number of regular inspection and monitoring tasks could also be executed by the mobile robot autonomously – thus without the need for supervision by a user. This includes:

- Monitoring of gauges, meters
- Inspection of remote operated valves
- Acoustic inspection
- Inspection of equipment for leakage
- Sample taking
- Maintenance of gas and fire sensors
- ...

A mobile robot for offshore inspection and manipulation may further be equipped with sensors and functions that exceed human perception and abilities, such as audio inspection with spectral analysis, for example of pumps and turbines or thermal imaging and image analysis of the platform equipment. Furthermore, the robot may be able to operate under severe weather conditions and in the reach of dangerous situations, where it would be unsafe for humans to work.

### Challenges of Applying Mobile Robot Technologies in Offshore Environments

In order to apply mobile robotics technologies in offshore environments, a number of challenges that do not exist in any other application area of mobile robots must be overcome:

The ambient temperature on offshore platforms shows significant variations depending on the platform's location. The mobile offshore robot must thus be operable in temperature ranges between  $-30$  and  $+50$  °C. Additionally, relative humidity up to 100 % and condensating, possibly highly radiant heat from process equipment, heavy precipitation, splash water, salty air, storms, and direct sunlight can be observed in some offshore locations. The mobile offshore robot must be suitable for these environmental conditions. In order to guarantee the safe operation in explosive atmospheres it must be explosion protected – and therefore be certified or as a prototype at least be certifiable according to relevant standards.

Typical manufacturing environments provide smooth concrete floors without bumps and gaps – suitable for hand lift trucks and AGVs (automatic guided vehicles). Offshore platforms on the other hand mainly consist of plain steel floor

and gratings – often with small holes, sharp edges, slopes and steps up to several centimetres in height, for example where different floor types attach (Fig. 2). As a requirement for the design of the mobile offshore robot, a “worst case” scenario, that is, a reference grating with maximum gap and step size and a reference slope with maximum gradient, must be considered.

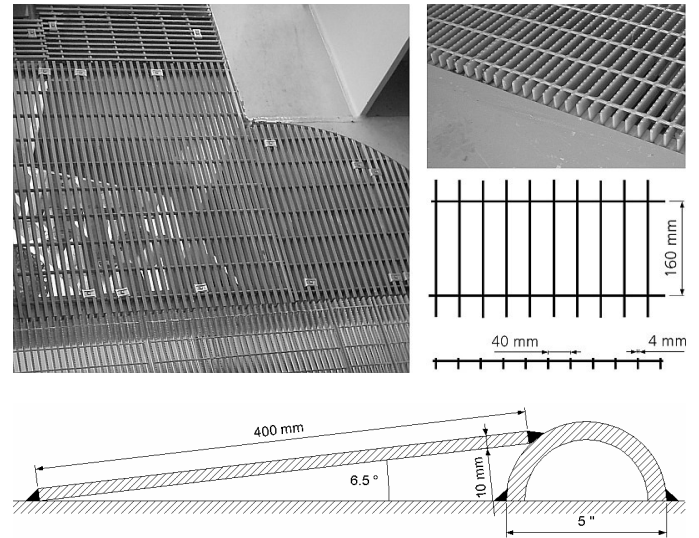

**Fig. 2: Floor conditions, reference grating and reference slope for a mobile offshore robot**

Whereas in typical manufacturing environments, mobile inspection and security robots or AGVs operate in wide corridors and clearly defined areas, an inspection and manipulation robot for offshore operation should be able to access most of the platform equipment. Passages between single machines are usually accessible by humans walking upright. The standards EN 547-1 and EN 547-3 (safety of machinery) define the dimensions required for openings for whole body access to machinery. To enable access for transporting an injured person, a minimum width of 745 mm is required (based on European anthropometric data). Indeed, even in highly cramped offshore environments, smaller passages can hardly be found. Based on that data, a reference passage the mobile offshore robot must be able to pass has been defined (Fig. 3).

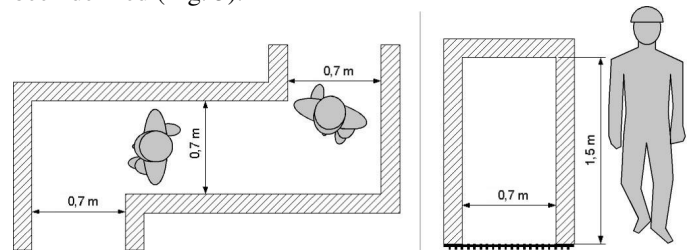

**Fig. 3: Reference passages for a mobile offshore robot**

Autonomous mobile robots are usually able to detect walls and other kinds of obstacles in their environment automatically and plan an appropriate optimal collision-free path [5]. Offshore installations contain complex structures such as pipes, flanges, tanks, steel frames, stairways and many more, which can be very hard to detect by sensor systems applied typically in mobile robotics. The environment sensors of the mobile offshore robot must be suitable to distinguish

relevant structures in the environment such as obstacles and free passages.

The process equipment on offshore platforms, especially on deep water installations, is distributed among different levels, often including intermediate or mezzanine levels. To move from one level to the other, only stairs or ladders are available. In order to access all levels by one single robot, an appropriate means to move the robot from one level to another is required.

### Hardware Design

The following section will discuss the requirements for the hardware design of a mobile offshore robot. After a quick review of existing hardware component according to the state of the art in mobile robotics, the required specs of a first realization of a mobile robot for offshore inspection and monitoring will be discussed.

### Requirements

In order to be suitable for dependable and useful offshore operation, the following basic requirements must be met by the hardware of the mobile inspection and manipulation robot:

- The robot must be certified – or as a prototype be certifiable – according to e.g. ATEX or IECEx.
- The drives system of the robot must be suitable for the very special floor conditions discussed previously.
- The robot has to manoeuvre in confined spaces; therefore its size must be adapted to the previously defined reference passage.
- The robot must be equipped with highly reliable sensors to perceive its surroundings, especially to detect obstacles.
- If the robot is supposed to navigate in different levels, an auxiliary drive unit can enable the robot to move vertically on simple ladder-type steel profiles.

Additionally, the following functional requirements can be derived from the application scenarios:

- The robot must be equipped with sensors to precisely track its position which is a key requirement for autonomous motion.
- The robot must be equipped with a manipulator to position sensors or grasp objects.
- The robot must be equipped with appropriate application sensors and tools required for the autonomous or tele-operated execution of inspection and manipulation tasks.
- The robot must be able to communicate with a central control station, for example by Wireless LAN.

### State of the Art

Several types of mobile robots for outdoor applications exist on the market such as military robots [6], or security robots [7]. The drives systems of most existing outdoor robots are designed for off-road environments and not suitable for high precision navigation. Furthermore, existing outdoor robots are usually purely tele-operated devices that do not provide the necessary sensors to adapt them for autonomous or semi-autonomous operation. Even though, some outdoor robots provide autonomous navigation capabilities, none of them is ATEX certified or can be modified to suit ATEX requirements.

The only mobile devices designed for hazardous areas and according to the standards for explosion protection, are industrial forklift trucks [8,9] for which there is also a standard in place (EN 1755). However, these vehicles are much too large to navigate with the confined spaces given in offshore environments.

To summarize, for the development of a mobile robot that is explosion protected and suitable for the above described application, no commercial mobile base is available. However, existing concepts and technologies of explosion protected industrial trucks as well as of mobile robots may be used and adapted for the design of the mobile offshore robot.

### Realization of the Robot Hardware

The first prototype realization of a mobile robot for offshore inspection and manipulation contains all hardware components required to safely execute simple inspection and monitoring tasks in offshore environments (Fig. 4). This first realization is able to navigate in one level only.

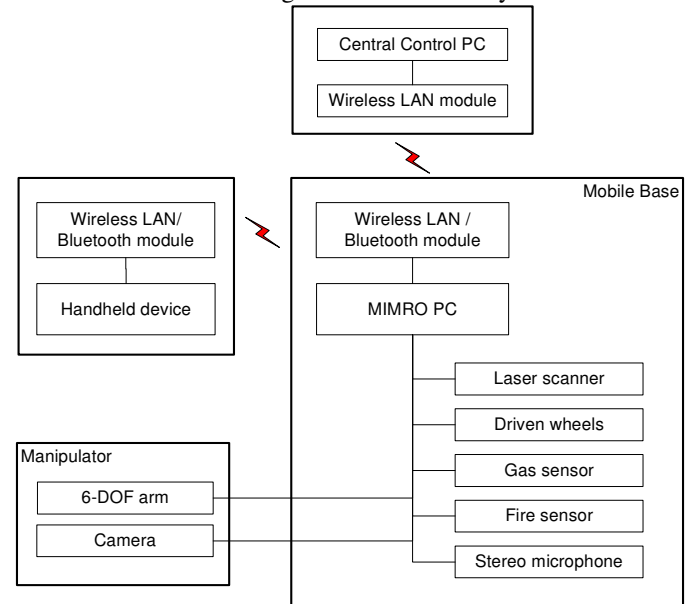

**Fig. 4: Hardware components of a mobile offshore inspection robot.**

The robot has a circular footprint with two driven wheels (differential drives) and two steering wheels. This design is common with many mobile robots since mechanics and motion control are simple and it allows turning on the spot in confined spaces. For environmental perception and motion tracking, a laser scanner and dead reckoning based on incremental encoders in the motors are used. The robot is equipped with a 6-axis robotic arm which carries a camera for visual inspection. Various application sensors such as stereo microphones, a gas and a fire sensor are attached to the robot base. Using lightweight materials for the mobile base and inner framework together with a low centre of gravity ensures the stability of the robot at all times. The system is designed to operate in Ex-Zone-1. Due to its innovative hybrid explosion protection concept it is certifiable according to IEC60079 standards of explosion protection. Using wireless LAN or Bluetooth the robot is able to communicate with a central control PC or with an external handheld device.

## Software Design

The following section will discuss the requirements for the control software of a mobile offshore robot, followed by a review of existing key technologies for autonomous or semi-autonomous mobile robots, specifically autonomous navigation capabilities. Finally, the required software design of a first realization of a mobile robot for offshore inspection and manipulation will be specified.

## Requirements

The control software for a mobile offshore robot should provide functions to

- navigate on the platform without collisions
  - in remote-controlled mode,
  - in automatic mode, for example move to a given target autonomously
- easily program typical inspection and monitoring tasks
- execute pre-programmed inspection and monitoring tasks automatically
- enable supervision and control of the robot from a remote location
- display sensor data such as camera images or the current gas concentration on the remote screen
- alert the remote operator when abnormal sensor values are detected
- review sensor recordings of past autonomous inspection tasks at the remote screen

In order to manoeuvre safely on offshore installations, apart from the specified requirements for the sensor hardware, additional challenges must be met by the navigation system of the robot. In narrow passages, the robot must follow a given path very precisely in order not to touch the platform equipment. In order to pass the long distances given on offshore installations with high velocities, the data of the environment sensors must be processed with high frequency and the motion of the robot adapted regularly. This imposes significant requirements to the sensor data acquisition and processing system.

In order to ease the workload of the robot remote operator, the control software of the robot should provide as much autonomous behaviour as possible. However, autonomous actions of the robot should at no time conflict with the intention of the user and the user should always be able to interrupt the autonomous operation of the robot and switch to manual control if necessary.

Most mobile robots applied in typical industrial applications can only be operated by specialists, regardless of whether they are remote controlled, programmable, or fully autonomous. However, a mobile robot for inspection and manipulation in offshore environments may only be acceptable if it can be used without expert knowledge but rather easily and intuitively as a daily-used tool. This implies that:

- new inspection and manipulation tasks can be programmed quickly and without the assistance of specialists,
- anyone working next to the robot can interact with it safely.

## State of the Art

Mobile robots are already able to navigate autonomously in structured environments such as office buildings, factories or museums. Navigation for mobile robots has evolved to a very safe and reliable technology in recent years – even when navigating among moving people [10, 11].

The capability of a mobile robot to autonomously plan and follow an optimal path to a given target is based on an environment map containing obstacles and free passages in the environment. Depending on the selected planner, additional optimization of the path is required. Fig. 5 shows an example for calculating a path to a given target with a potential field planner, path smoothing, and adapting the path after a dynamic obstacle has been detected.

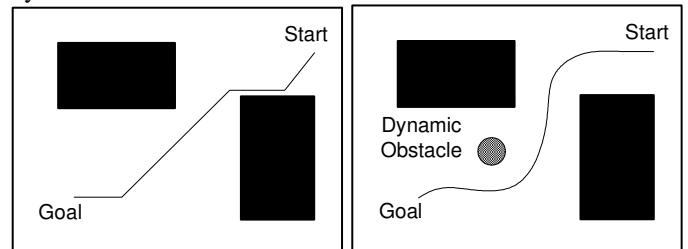

**Fig. 5: Autonomous path planning based on known obstacles available in the environment (black boxes) and path adaptation**

The required environment map can be obtained from environment models such as CAD drawings or by the robot itself. For automatic mapping, the robot is driven manually through the environment, for example with a joystick, and autonomously records the location of specific environment features such as walls or pipes [12]. In addition to the features detected automatically by the environment sensors of the robot, in a second step, prohibited areas or virtual walls around sensitive areas can be added manually to the map by the user.

During both, autonomous and tele-operated motion, the mobile offshore inspection robot must be aware of its precise position in the given operation environment. The position is important to know in order to automatically avoid prohibited areas and thus guarantee the safe operation of the robot. A similar environment map as for the path planning can be used for precise self-localization of a mobile robot. Comparing the environment map with the currently measured environment features is a method used widely in mobile robotics to calculate the current position of the robot (Fig. 6).

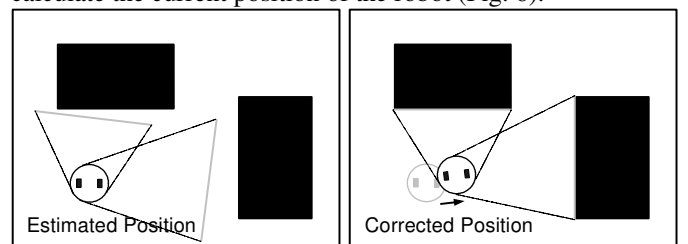

**Fig. 6: Localizing a mobile robot by aligning detected walls (grey lines) with obstacles (black boxes) in the environment map.**

Graphical user interfaces including touch screen control are used frequently for most mobile robot control. New technologies include speech and gesture control as well as haptic interfaces enabling direct feedback on the robot's environment [13]. As the user interface of the robot is highly specific for the given application, basic concepts of man-

machine-interaction technologies can be used; however, the global concept of the user interaction system must be designed specifically for the offshore application.

### Realization of the Robot Control Software

The most important capability for the first prototype realization of a mobile offshore inspection robot is its ability to navigate safely in offshore environments. Based on this function, the robot is able to automatically execute inspection tasks, for example autonomously record sensor data at important locations or to perform continuous sensor recordings along a pre-defined path. The results of all executed inspection tasks are saved to a database and can be reviewed by the responsible operator in the central control room at any time.

Inspection tasks are programmed to the robot using a handheld device, for example an explosion proof PDA with the operator located close to the robot for supervision. After successfully programming all necessary inspection tasks, the operator can remain in the control room whereas the robot executes the programmed tasks autonomously.

In order to program the recording of sensor data at a specific location, the following steps are required:

1. The robot is driven to the designate inspection position using the integrated joystick of the handheld device. The position of the robot is saved as the target position of a new inspection task. The inspection task is given a unique name and task description for further identification.
2. If a camera image or video stream is to be recorded by the camera, the robot arm can now be moved to the point of inspection also using the integrated joystick of the handheld device. The performed arm motion is saved as an operation of the current inspection task.
3. The type of sensor data that needs to be saved at this position is selected on the handheld device.
4. The arm is moved back to its home position which ensures that when moving on to the next inspection position, the robot safely passes all passages of the previously defined minimum height and width.

Continuous sensor recordings are programmed similarly. After step 1, the following actions are required:

5. The type and interval of the desired sensor recording is specified on the handheld device
6. The inspection path of the robot is programmed by moving it through the environment using the integrated joystick of the handheld device.

In order to prove the correct execution of an inspection task, work orders can be tested on the robot directly after programming. After the successful test, the new inspection task is saved to the central database.

Using the central control PC, all existing inspection tasks can be read from the database and listed on the screen. They can be grouped together as so called "work sequences" and loaded to the robot for execution. In order to execute a sequence of previously recorded inspection tasks, the following steps need to be executed by the operator:

1. Read available inspection tasks from the database.
2. Select tasks to be executed.
3. Save work sequence containing selected inspection tasks under a specific name. The same work sequence can be

executed again at any other time.

4. Start execution of work sequence by pressing the start button. Robot will start autonomous operation.
5. React to special alerts from the robot, for example in case of unexpected situations (unexpected obstacle detected, high gas concentration etc.)
6. Stop autonomous work sequence execution at any time by pressing the stop button on the graphical user interface.

Reviewing previously recorded inspection on the central control PC tasks is also rather straight forward:

1. Select name of inspection task for review
2. Specify date and time of recording
3. Specify sensor type

The values and location of the selected sensor recordings will be displayed on the screen.

Apart from configuring, executing and reviewing autonomous inspection tasks, the central control PC enables environment supervision by the operator in real time. All relevant sensor data such as current gas concentration, current camera image etc. is continuously displayed on the screen. Additionally, the current sound in the robot's environment is getting transferred to the central control PC. The status of internal resources such as the current battery status is also displayed on the graphical user interface. In case the battery of the robot runs low, it will automatically return to its home position for charging.

### Field Test

The correct function of the navigation system as the most crucial software component for a mobile offshore robot was first tested at the Fraunhofer IPA labs. For localization, the mobile offshore robot uses specifically shaped objects such as pipes and poles as well as stripes of reflective tape applied to the environment. The testing area of the robot was therefore equipped with a large number of similarly shaped objects (Fig. 7). The test area covered approximately 40 x 80 meters. The environment map was generated by the robot automatically (Fig. 8).



Fig. 7: Environment setup for navigation tests.



Fig. 8: Environment map and driven path for navigation tests (black: detected obstacles, white: free space, grey: unknown).

Several exemplary inspection tasks were programmed to and afterwards executed autonomously by the robot successfully.

After having passed stringent safety assessments and a factory acceptance test, the mobile offshore inspection robot was tested on an offshore gas platform (Fig. 9). During the testing period, the robot was running continuously for 12 hours per day in hazardous locations, more precisely in zone 2 and zone 1 environments. It was running in tropical environment with 35+ °C ambient temperature, up to 90 % rel. humidity, and direct sunlight. Temporarily, heavy rain and stormy gusts up to 45 knots occurred.

An environment map was generated automatically by the robot covering an area of approximately 135 x 110 m (Fig. 10).



**Fig. 9: Offshore platform for real environment testing (aerial view and view of production platform equipped with reflector poles for localization)**

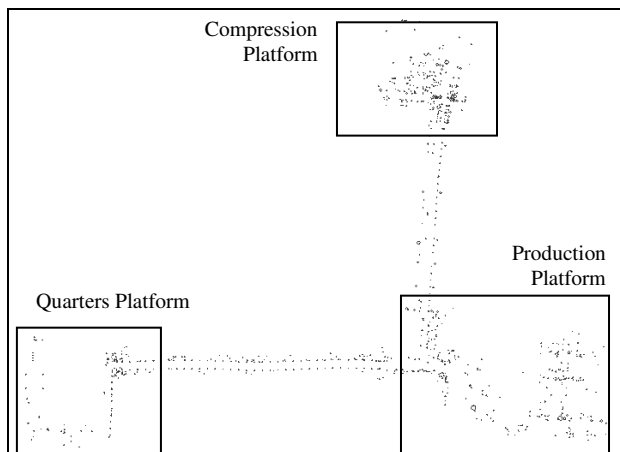

**Fig. 10: Environment map for offshore tests (black: detected environment features, white: free space).**

Several inspection tasks, mainly gauge reading and monitoring of gas concentrations were taught to and executed by the robot successfully (Fig. 11). The robot proved its ability to navigate safely in the offshore environment and execute inspection tasks autonomously. At no time did it jeopardize the safety of the equipment or the platform personnel.



**Fig. 11: Mobile inspection robot executing inspection tasks on an offshore gas platform.**

## Conclusions and Outlook

The evaluation of the first autonomous service robot that has ever been operated in offshore environments has proven the applicability of mobile robots to offshore platforms. Different types of inspection tasks (visual and acoustic inspection, gas measuring) have been programmed to and executed by the robot successfully without ever jeopardizing the safety of the platform or the platform personnel.

Future developments will increase the functionality and dependability in specific environmental conditions and add new functionalities to the mobile inspection and manipulation robot.

## References

1. IFR Statistical Department: "World Robotics 2006" <http://www.worldrobotics.org> (5.7.2007).
2. Oceaneering International, Inc.: "Remotely Operated Vehicles" 2005-2006 <http://www.oceaneering.com/ROVs.asp> (5.7.2007)
3. Virk, G.S.: "Industrial mobile robots: the Future", *Industrial Robot Journal* 24 (1997), No. 2, pp. 102-105
4. Kohlhepp, P.; Bretthauer, G.: "Cooperative Service Robots for the Predictive Maintenance of Process Plants". In: Proc. Int. Colloq. on Autonomous and Mobile Systems, Magdeburg, GERMANY, 25.-26. June 2002, pp. 53-60.
5. Latombe, J.-C.: *Robot Motion Planning*. Kluwer Academic Publishers, UK, 1996.
6. Foster-Miller, Inc.: "Products & Services. TALON Military Robots, EOD, SWORDS, and Hazmat Robots". <http://www.foster-miller.com/lemming.htm> (5.7.2007)
7. Robowatch Technologies GmbH: "BUSINESS UNIT SECURITY SYSTEMS" 2006 <http://www.robowatch.de> (5.7.2007)
8. Servolift LLC: "Explosion Proof AC Forklift Trucks by Sichelschmidt" <http://www.servo-lift.com/sichelschmidt/> (5.7.2007)
9. MIAG Fahrzeugbau GmbH: "Products" 2007 <http://www.miag.eu/Produkte/produkte.html> (5.7.2007)
10. Graf, Birgit: „Dependability of Mobile Robots in Direct Interaction with Humans.“ In: Prassler, Erwin (Ed.) u.a.: *Advances in Human-Robot Interaction*. Berlin u.a.: Springer, 2005, pp. 223-239 (Springer Tracts in Advanced Robotics - STAR 14).
11. Quinlan, Sean; Khatib, Oussama: Elastic Bands: Connecting Path Planning and Control. In: IEEE International Conference on Robotics and Automation, 1993, pp. 802-807.
12. Thrun, Sebastian: „Robotic Mapping: A Survey.“ Technical Report CMU-CS-02-111, Carnegie Mellon University, Computer Science Department, Pittsburgh, PA, USA, 2002.
13. Kubacki, Jens; Reiser, Ulrich: „Mirrobot: Fast Detection of Body-Parts in the Scale-Space of Range Images with an Application to Human Motion Copying.“ In: Dautenhahn, Kerstin (Conf. Chair); Institute of Electrical and Electronics Engineers u.a.: *IEEE RO-MAN 2006*, 6-8 September, 2006, University of Hertfordshire, Hatfield, UK. Piscataway, N.J., USA: IEEE, 2006, pp. 552-557.